

SFCL and Applications Study for Implementation in Electrical Power System

Devanand Kumar
M.Tech
IES College of Technology
Bhopal (M.P.), India
dkyashraj@gmail.com

Jyoti Bansal
Asst. Professor
IES College of Technology
Bhopal (M.P.), India
jyotig1979@gmail.com

Abstract: The increase in demand and consumption of electricity has led to an increase in system errors. Superconducting Residual Current Limiters (SFCLs) provide ideal performance in the power grid. The concept of superconducting fault current limiters (SFCLs) suggests two types of superconducting materials. First of all Resistive-SFCL (which is inserted directly in series with the circuit to be protected). Second, the inductive SFCL (a transformer shorted by a superconducting tube). We also explore some uses of the proposed SFCLs to limit the fault current that appears in the electrical network. The fault current level has become a major problem in the operation of transmission and distribution systems. Applying the superconducting residual current limiter (SFCL) would not only reduce the load on the equipment in the network, but can also provide a link to improve the reliability of the power system. They also make the electricity grid more efficient and more integrated.

Keywords: SFCL, fault current, High Temperature Superconductors, high voltage.

I. INTRODUCTION

The ever increasing demand for electricity had led to larger sizes of power plants and interconnected distribution networks called power grids, with the risk of increasing abnormal operation. Traditional circuit breakers cannot be used in the network because rising fault current levels may soon exceed their rated fault current breaking capacity. This increasing fault current leads to the replacement of a large number of devices in power systems such as transformers and circuit breakers. Superconducting Residual Current Limiter (SFCL) is one of the most innovative alternative solutions to avoid the problem of increasing residual current. It improves the reliability and stability of the power supply system by immediately reducing the fault current [1]. SFCLs have high impedance under fault conditions and very low impedance under normal conditions, as well as instant zero impedance, reset after troubleshooting. Superconducting materials have highly non-linear behavior which is ideal for use as an FCL.

A. Superconductors to SFCLS

The Superconducting Fault Current Limiter (SFCL) has unique properties inherited from the properties of superconductors. This chapter presents the basic elements of superconductivity, with which the origin of the electrical resistance that occurs in the flow-flow regime in high-temperature superconductors is presented. Superconductivity is a state of affairs characterized by a weak attractive interaction between conduction electrons. In this particular state, which occurs for many elements of the periodic system, this weak interaction reduces the entropy of the system and allows the phase movement of related electrons over large distances. This long-range phase coherence is believed to be responsible for the perfect conductivity observed in superconductors. In addition to zero resistance, ideal superconductors are characterized by perfect and reversible diamagnetism.

This special behavior is known as the Meissner effect, i. H. The absence of magnetic flux in the mass of the material for all initial conditions. These unique characteristics of the superconducting state are overcome when an external energy input (thermal, magnetic or kinetic) is sufficient to upset the balance of the brittle phase. In particular, the superconductor becomes a normal metal when the critical surface defined by the critical values (temperature, magnetic field and current density) is reached, as shown in fig. 1.1.

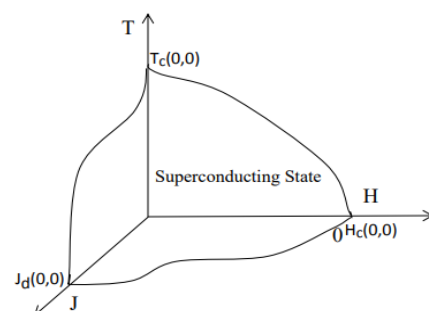

Fig 1: The critical surface of a Superconductor

II. LITERATURE REVIEW

G.Didier et al. [2] here we suggest comparing rSFCL and iSFCL if a fault occurs in a simple high voltage (HV) network (IEEE 3 bus test system). To evaluate the impact of SFCL in the power system under consideration, a time domain approach is used to evaluate the short circuit current in the power system by solving the differential equations of that circuit configuration for different SFCL impedances. For the transient stability study, the authors use a same surface criterion approach to evaluate the critical compensation angle (CCA) and a time domain approach to evaluate the critical compensation time (CCT) for two types of SFCL.

S. Nemdili,S. Belkhiat [3] suggests an electro thermal model of coated conductors in the Matlab library which is much easier than other literature such as FEM to solve equations that define the properties of the superconducting material. It also shows a better configuration of the HTS cable to use as SFCL on different lengths.

SoumenKar et al. [4] Electro thermal modeling is performed to calculate fault current limitation, resistance, and temperature rise. The results showed fast response time and immediate recovery, validating the model for use in electrical installations.

Y. Chen et al. [5] conducted an experiment with a 10kV / 200A SFCL resistive type prototype and performed various tests including short circuit test, recovery test and LN2 boil test. The results show a 30% to 70% reduction in fault current and the recovery time over fault duration shows a linear relationship.

III. SUPERCONDUCTING FAULT CURRENT LIMITER

The SFCL is a device that can limit the amount of residual current in the first residual current cycle, while the circuit breaker requires two to three residual current cycles. The application of SFCL in the electrical system would not only reduce the load on the system devices, but would also improve the safety and reliability of the electrical system [6]. There are different types of SFCL, which have different structures and are made from a superconducting material. Fig. 2 shows the current with and without SFCL under different operating conditions [6]. SFCL was first produced in 1983 using a low temperature material. The material was NbTi with excellent current carrying capacity, but the low temperature superconductor (LTS) has one drawback. The cooling costs were very high. To overcome this drawback, high temperature superconductors (HTS) are being developed. The HTS fault current limiter is more satisfactory than the LTS fault current limiter because,

- (i) More effective thermal stability

- (ii) Less Refrigeration cost
- (iii) High ordinary specific resistance

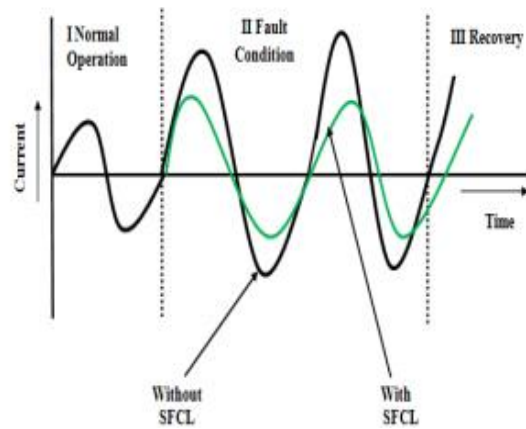

Fig.2 Current during Normal and Faulty Condition with and without SFCL

In order to improve the capacity of the current HTS, the HTS have been designed to meet the needs of the electrical system. Superconductor parallel to the substrate to limit the resistance of the SFCL in the normal state. Therefore, SFCLs are made using Bi-2223, Bi2212 films. YBCO, ZrO2 (Y), SrTiO3 and MgO are generally used as substrate materials. There, the specific resistance is about 100 times that of a normal superconducting material. 2 shows the parallel impedance ZSH SFCL to reduce the hotspot problem when switching from superconducting state to normal state.

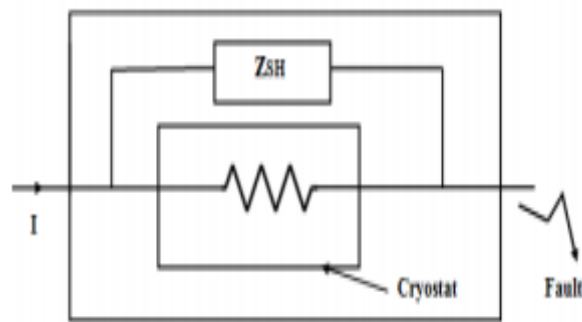

Fig.3 SFCL with Cooling System

IV. SFCL APPLICATIONS IN POWER SYSTEM

In a power system an SFCL can be placed at different location such as: (i) Feeder Point (ii) Bus-Tie Location (iii) Busbar Coupling

- (i) SFCL at the branch point The resistor type SFCL can be used in both outgoing and incoming branches as a transformer branch. It depends on the safety task shown in Figure 4. This application provides protection for all downstream components upon installation. The

classification of the device changes depending on the selected location [7].

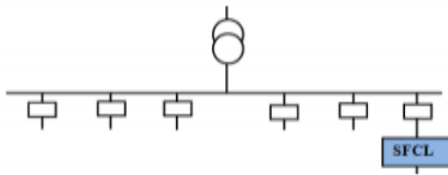

Fig.4 SFCL in feeder point

(ii) SFCL at the bus connection point Arranging the SFCL at a bus connection point offers significant advantages when bypassing bus sections taking into account the loss of one or more transformers in the substation. This is shown in Figure 5. It also offers parallel connection of bus sections in previously divided substations, more flexible arrangements that allow for interconnection and better power quality. Depending on the required error reduction and the busbar topology, one or more SFCLs can be installed with minimal modifications to existing protective devices [8].

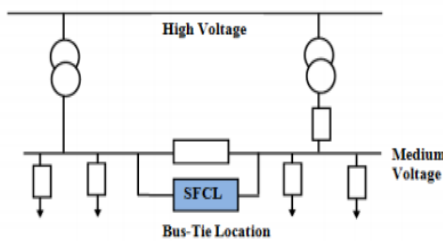

Fig. 5 SFCL in Bus-Tie Location

(iii) Busbar Coupling The resistor type SFCL is preferable primarily for busbar coupling. This is shown in Figure 6. In an error state, this limiter ensures that the short circuit power of the non-defective bus is greatly reduced. The healthy side can withstand nearly stable functioning and tension [9]

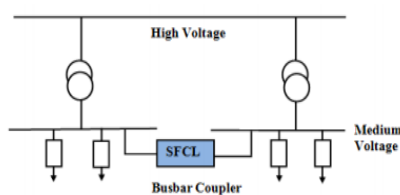

Fig. 6 SFCL in Busbar coupling

V. RESISTIVE TYPE SUPERCONDUCTING FAULT CURRENT LIMITERS

Heavy Duty Superconducting Residual Current Limiters (SFCLs), manufactured with High Temperature Superconducting Tapes (HTS), offer the most operational and reliable protection against fault transition due to their characteristic behavior of high critical current density and rapid super conduction to normal (Y / N) state. Resistor-type

SFCLs are shown in series with the source and load (Fig. 3). During normal operation, the current flowing through the RSC superconducting element dissipates a low energy. When the current exceeds the critical current value, the RSC resistance increases rapidly. The dissipated losses due to the rapid increase in resistance heat the superconductor above the critical temperature T_c and the superconductor RSC changes its state from superconducting to normal and the fault current is immediately reduced. This phenomenon is known as superconductor cancellation. When the fault current has been reduced, the RSC element restores its superconducting state. The parallel resistor or the inductive shunt ZSH is needed to avoid hot spots during shutdown, to set the limiting current and to avoid overvoltage due to fast current limits. Resistive SFCLs are much smaller and lighter than inductive ones. They are subject to excessive heat during the shutdown state.

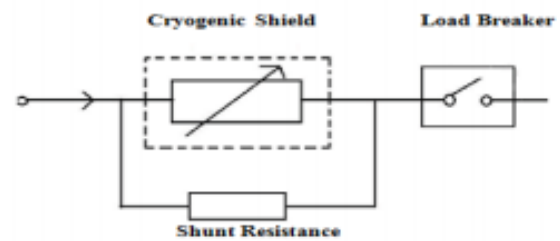

Fig.7 RSFCL Circuit Diagram

VI. INDUCTIVE TYPE SUPERCONDUCTING FAULT CURRENT LIMITER (ISFCL)

An inductive core of saturated iron SFCL is shown in Fig. It consists of two iron cores powered by a DC bias supply. Two iron cores are used which can limit the fault current in both directions. Inductive SFCL has unique advantages such as great design flexibility due to rotation ratio, isolation between a power transmission line, current limiting devices and low heat loss [10]. The winding temperature of the inductive SFCL is higher than that of the resistive SFCL. The primary current during a fault is greater than a secondary current. The inductive SFCL design should have a considerable length of superconducting tape that would be required by the high voltage. With the inductive limiter, the HTS sockets on the primary section provide both inductance and resistance.

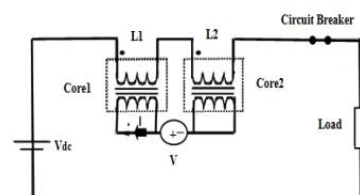

Fig.8 Inductive SFCL Circuit Diagram

VII. FAULT CURRENT LIMITERS

A fault current limiter (FCL) is a device that limits the probable fault current in the event of a fault on the electrical network. It reduces residual currents to a lower manageable level and allows the use of protection devices of lower rated power. The recent trend towards deregulation and restructuring of the electricity grid has sparked renewed interest in FCL technologies for the implementation of reliable and economically viable commercial equipment. Several types of fault current limiters have recently been developed.

VIII. BENEFITS OF FAULT CURRENT LIMITERS

The main advantage of the residual current limiter is to save the cost of removing low power equipment and installing higher power equipment in existing installations, as it reduces the residual current value that the existing protection device can handle. FCLs are installed in each phase of the line and add an impedance in series to limit the fault current to an acceptable level. FCLs reduce the short circuit level and thus ensure safer system operation. With these devices installed in the circuit, parallel paths can be connected to each other to improve reliability regardless of the increase in total short circuit level. Reduction or elimination of power outages in the area, reduction of localized noise and longer recovery times in the event of disturbances.

IX. IDEAL FAULT CURRENT LIMITER

An ideal residual current limiter should have the following properties:

- Invisible during normal system operation; H. Enter zero impedance in the system if there are no faults in the system.
- Insert a high impedance when a fault occurs in the system.
- Work in the first cycle of the fault current.
- It should reset briefly, ie H. Return to normal operation immediately after limiting the fault current value.
- It should work automatically and return to normal.
- Can be used repeatedly and should have a long service life.
- The coordination of the relay must not be altered.
- It should be small and inexpensive.

X. CONCLUSION

FCLs offer the potential to increase the utilization of distribution and transmission equipment and reduce the need for amplification. Extensive research is needed not only for building new FCL devices, but also for how they function in the system under different conditions. In recent years, FCL technology based on superconductivity and solid state has gained more attention. In fact, with the advent of high

temperature superconducting (HTS) cables, cooling costs have dropped significantly. With the advancement of high performance switching technology, solid state limiters have become useful devices. These, along with superconductors, are the most promising types of FCL of the future. Significant advances in technological development led to the first commercially available resistive FCL based on high temperature superconductors for medium voltage levels. This article introduces resistive and inductive superconducting fault current limiters. The limitation and benefits of the fault current are described.

REFERENCES

- [1] Xiaoze Pei, "Superconducting Fault Current Limiter with Integrated Vacuum Interrupter," PhD Thesis, University of Manchester, United Kingdom, 2012.
- [2] G. Didier, C.H. Bonnard "Comparison between inductive and resistive SFCL in terms of current limitation and power system transient stability", Electric Power Systems Research, Volume 125, August 2015, Pages 150-158
- [3] Nemdili, S., and SaadBelkhiat. "Electrothermal modeling of coated conductor for a resistive superconducting fault-current limiter." *Journal of Superconductivity and Novel Magnetism* (2012): 1-8
- [4] SoumenKar, Sandeep Kulkarni, S. K. Sarangi, and V. V. Rao," Conceptual Design of a 440V/800 A Resistive-Type Superconducting Fault Current Limiter Based on High Tc Coated Conductors", *IEEE Trans. Applied Superconductivity*, vol. 22, no. 5, october 2012.
- [5] Y. Chen, S. Li, J. Sheng, Z. Jin, Z. Hong, J. Gu, " Experimental and Numerical Study of Coordination of Resistive-Type Superconductor Fault Current Limiter and Relay Protection" *J Supercond Nov Magn* (2013) 26:3225–3230.
- [6] Shilpi Yadav, Kamlesh Bharati "Superconducting Fault Current Limiter-A Review", *International Journal of Applied Engineering Research* ISSN 0973-4562 Volume 14, Number 2, 2019.
- [7] J Bock, A. Hobl, J. Schramm, S. Krämer, and C. Jänke, "Resistive Superconducting Fault Current Limiters Are Becoming a Mature Technology," *IEEE Transactions on Applied Superconductivity*, Vol. 25, No. 3, pp. 2–5, 2015.
- [8] [15] B. Shu, X. N. Li, K. Zhang, X. Sun, W. Li, Z. Y. Liu, Q. H. Lou, Y. Liu, and B. Q. Yao, "Behaviors and Application Prospects of Superconducting Fault Current Limiters in Power Grids," *IEEE Transactions on Applied Superconductivity* Vol. 24, No. 5, 2014.
- [9] [16] S. Kozak, T. Janowski, G. Wojtasiewicz, J. Kozak, B. Kondratowicz-kucewicz, and M. Majka, "The 15 kV Class Inductive SFCL," *IEEE Transactions on Applied Superconductivity*, Vol. 20, No. 3, pp. 1203–1206, 2010.
- [10] J. Kozak, M. Majka, S. Kozak, and T. Janowski, "Comparison of Inductive and Resistive SFCL," *IEEE Transactions on Applied Superconductivity*, Vol. 23, No. 3, pp. 6–9, 2013.